

Symmetra™ PX

48 kW 400 V, 96 kW 400 V,
100 kW 208 V, 160 kW 400 V

Receiving and Unpacking

9/2023



Legal Information

The Schneider Electric brand and any trademarks of Schneider Electric SE and its subsidiaries referred to in this guide are the property of Schneider Electric SE or its subsidiaries. All other brands may be trademarks of their respective owners.

This guide and its content are protected under applicable copyright laws and furnished for informational use only. No part of this guide may be reproduced or transmitted in any form or by any means (electronic, mechanical, photocopying, recording, or otherwise), for any purpose, without the prior written permission of Schneider Electric.

Schneider Electric does not grant any right or license for commercial use of the guide or its content, except for a non-exclusive and personal license to consult it on an "as is" basis. Schneider Electric products and equipment should be installed, operated, serviced, and maintained only by qualified personnel.

As standards, specifications, and designs change from time to time, information contained in this guide may be subject to change without notice.

To the extent permitted by applicable law, no responsibility or liability is assumed by Schneider Electric and its subsidiaries for any errors or omissions in the informational content of this material or consequences arising out of or resulting from the use of the information contained herein.

Table of Contents

Important Safety Instructions — SAVE THESE INSTRUCTIONS	7
Safety Precautions	8
Storage Conditions.....	9
Weights and Dimensions	9
Receiving	12
Move to Installation Site	13
Clearance Symmetra PX 48 kW	13
Clearance for 300 mm Cabinets	14
Clearance Symmetra PX 100 kW	15
Clearance Symmetra PX 96 and 160 kW	16
Unpack the Cabinets.....	17
Documentation Storage.....	21

Important Safety Instructions — SAVE THESE INSTRUCTIONS

Read these instructions carefully and look at the equipment to become familiar with it before trying to install, operate, service or maintain it. The following safety messages may appear throughout this manual or on the equipment to warn of potential hazards or to call attention to information that clarifies or simplifies a procedure.



The addition of this symbol to a “Danger” or “Warning” safety message indicates that an electrical hazard exists which will result in personal injury if the instructions are not followed.



This is the safety alert symbol. It is used to alert you to potential personal injury hazards. Obey all safety messages with this symbol to avoid possible injury or death.

DANGER

DANGER indicates a hazardous situation which, if not avoided, **will result in** death or serious injury.

Failure to follow these instructions will result in death or serious injury.

WARNING

WARNING indicates a hazardous situation which, if not avoided, **could result in** death or serious injury.

Failure to follow these instructions can result in death, serious injury, or equipment damage.

CAUTION

CAUTION indicates a hazardous situation which, if not avoided, **could result in** minor or moderate injury.

Failure to follow these instructions can result in injury or equipment damage.

NOTICE

NOTICE is used to address practices not related to physical injury. The safety alert symbol shall not be used with this type of safety message.

Failure to follow these instructions can result in equipment damage.

Please Note

Electrical equipment should only be installed, operated, serviced, and maintained by qualified personnel. No responsibility is assumed by Schneider Electric for any consequences arising out of the use of this material.

A qualified person is one who has skills and knowledge related to the construction, installation, and operation of electrical equipment and has received safety training to recognize and avoid the hazards involved.

Per IEC 62040-1: "Uninterruptible power systems (UPS) -- Part 1: Safety Requirements," this equipment, including battery access, must be inspected, installed and maintained by a skilled person.

The skilled person is a person with relevant education and experience to enable him or her to perceive risks and to avoid hazards which the equipment can create (reference IEC 62040, section 3.102).

Safety Precautions

⚠ WARNING

HAZARD OF ELECTRIC SHOCK, EXPLOSION, OR ARC FLASH

- Do not unpack the units before the time of installation.
- Cover the units and store the units in a temperature controlled indoor environment free of conductive contaminants and humidity, where the units are protected from moisture until the time of start-up. Moisture inside the cabinet can create hazardous short circuits.

Failure to follow these instructions can result in death, serious injury, or equipment damage.



NOTICE

RISK OF EQUIPMENT DAMAGE

- Wait until the system is ready to be powered up before installing batteries in the system. The time duration from battery installation until the UPS system is powered up must not exceed 72 hours or 3 days.
- Batteries must not be stored more than six months due to the requirement of recharging. If the UPS system remains de-energized for a long period, Schneider Electric recommends that you energize the UPS system for a period of 24 hours at least once every month. This charges the batteries, thus avoiding irreversible damage.

Failure to follow these instructions can result in equipment damage.

Storage Conditions

		
Storage temperature: -15 °C to 40 °C (5 °F to 104 °F)	Relative humidity: 0–95% non-condensing	Altitude: 0–15000 m (0–50000 ft)

Weights and Dimensions

Cabinets

	Weight kg (lbs)	Height mm (in)	Width mm (in)	Depth mm (in)
48 kW System (SYCF48KH)				
Packaged	331 (729)	2140 (84)	848 (33.3)	1210 (47.6)
Unpackaged	307 (679)	2011 (79.1)	600 (23.6)	1070 (42.1)
100 kW UPS (SYCF100KF)				
Packaged	386 (851)	2140 (84)	848 (33.3)	1210 (47.6)
Unpackaged	341 (752)	2011 (79.1)	600 (23.6)	1070 (42.1)
96 and 160 kW UPS (SYCF160KH)				

	Weight kg (lbs)	Height mm (in)	Width mm (in)	Depth mm (in)
Packaged	358 (789)	2140 (84)	848 (33.3)	1210 (47.6)
Unpackaged	325 (716)	2011 (79.1)	600 (23.6)	1070 (42.1)
Modular battery cabinet (SYCFXR9 and SYCFXR48)				
Packaged	379 (835)	2150 (84.6)	848 (33.3)	1210 (47.6)
Unpackaged	345 (760)	1996 (78.5)	600 (23.6)	1070 (42.1)
PDU-XR (PDUM160H-B)				
Packaged	444 (978)	2150 (84.6)	848 (33.3)	1210 (47.6)
Unpackaged	411 (904)	2004 (78.8)	600 (23.6)	1070 (42.1)
PDU (PDPM100F6F-M, PDPM100G6F-M, PDPM100L6F-M)				
Packaged	862 (1900)	2150 (84.6)	1016 (40)	1210 (47.6)
Unpackaged	816 (1800)	2004 (78.8)	600 (23.6)	1070 (42.1)
PDU (PDPM100F-M)				
Packaged	454 (1000)	2150 (84.6)	1016 (40)	1210 (47.6)
Unpackaged	408 (900)	2004 (78.8)	600 (23.6)	1070 (42.1)
Maintenance Bypass Panel (SYMBP100F, SYMBP160H)				
Packaged	189 (416)	2150 (84.6)	848 (33.3)	1210 (47.6)
Unpackaged	169 (371)	2004 (78.8)	300 (11.8)	1070 (42.1)
Side Car for Bottom Cable Entry (PDPM100SC)				
Packaged	159 (350)	2150 (84.6)	848 (33.3)	1210 (47.6)
Unpackaged	138 (305)	2004 (78.8)	300 (11.8)	1070 (42.1)
Side Car for Bottom Cable Entry (PDPM150SC)				
Packaged	155 (341)	2150 (84.6)	848 (33.3)	1210 (47.6)
Unpackaged	134 (295)	2004 (78.8)	300 (11.8)	1070 (42.1)

Modules

	Weight kg (lbs)	Height mm (in)	Width mm (in)	Depth mm (in)
Battery Unit (SYBTU2-PLP, SYBTU2-PLPLL)				
Packaged	27 (59.2)	180 (7)	150 (5.9)	810 (31.89)

	Weight kg (lbs)	Height mm (in)	Width mm (in)	Depth mm (in)
Unpackaged	25.2 (55.3)	159 (6.2)	107 (4.2)	700 (27.5)
Power Module — 400 V (SYPM10K16H)				
Packaged	31.5 (69.5)	225 (8.8)	595 (23.4)	795 (31.3)
Unpackaged	28.5 (62.8)	132 (5.2)	483 (19)	700 (27.5)
Power Module — 208 V (SYPM10KF2)				
Packaged	28.45 (61.7)	225 (8.8)	595 (23.4)	795 (31.3)
Unpackaged	25.1 (55.1)	132 (5.2)	483 (19)	700 (27.5)

Receiving

External Inspection

When the shipment arrives, inspect the shipping materials for any signs of damage or mishandling. Check tilt and impact indicators. Do not attempt to install the system if any damage is apparent. If any damage is noted, contact Schneider Electric customer support and file a damage claim with the shipping agency within 24 hours of receipt.

Compare the components of the shipment with the bill of lading. Report any missing items to the carrier and to Schneider Electric customer support immediately.

Verify that labelled units match the order confirmation.

Move to Installation Site

NOTICE

HAZARD OF EQUIPMENT DAMAGE

- Do not tip the cabinet more than 10° as it will cause damage to the cabinet.
- Ensure that the floor and the subfloor can support the total weight of the system, especially when the weight is concentrated on the stabilizing feet.
- Ensure that the floor is level. The cabinet cannot be installed on a floor that is not level.
- Use a pallet jack or a forklift to move the pallets to the installation site.
- If the height of the cabinet exceeds the height of the doorway, remove the cabinet from the pallet.

Failure to follow these instructions can result in equipment damage.

Clearance Symmetra PX 48 kW

NOTE: Clearance dimensions are published for airflow and service access only. Consult with the local safety codes and standards for additional requirements in your local area.

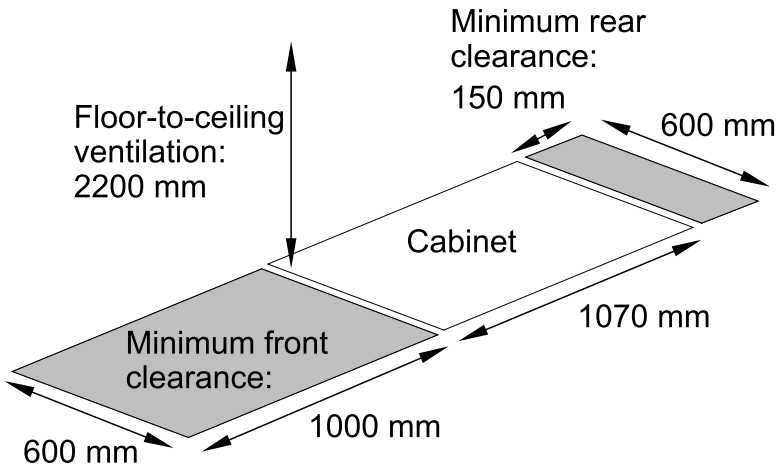

Clearance for 300 mm Cabinets

NOTE: Clearance dimensions are published for airflow and service access only. Consult with the local safety codes and standards for additional requirements in your local area.

NOTE: The rear clearance for the maintenance bypass panel is 900 mm.
The rear clearance for the sidecar for bottom cable entry (PDPM100SC) is 900 mm.
The rear clearance for the sidecar for bottom cable entry (PDPM150SC) is 700 mm.

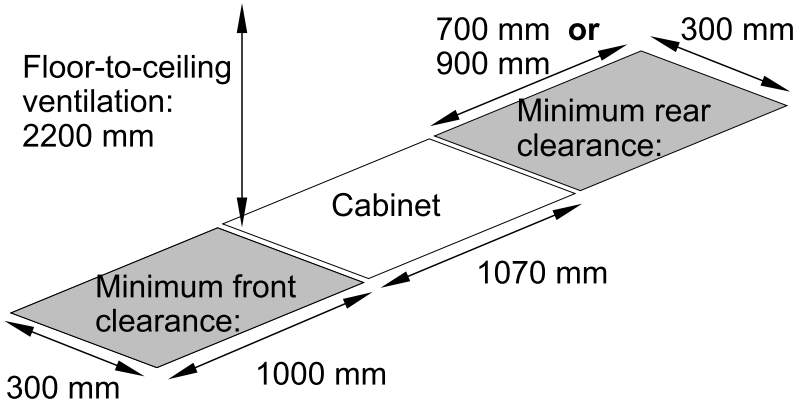

Clearance Symmetra PX 100 kW

NOTE: Clearance dimensions are published for airflow and service access only. Consult with the local safety codes and standards for additional requirements in your local area.

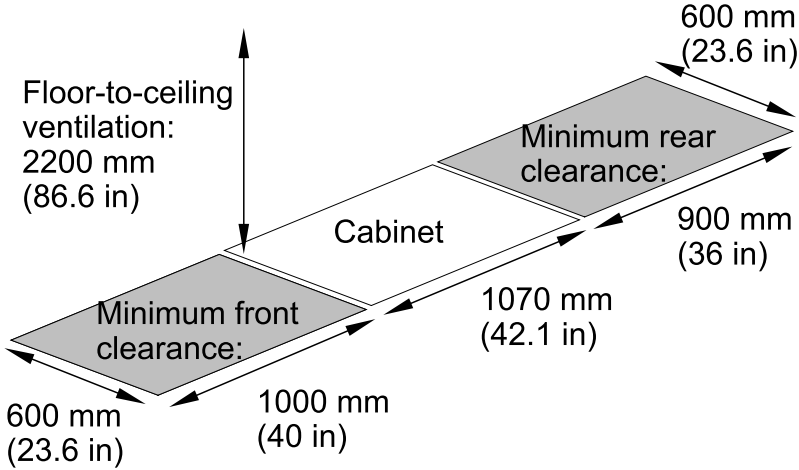

Clearance Symmetra PX 96 and 160 kW

NOTE: Clearance dimensions are published for airflow and service access only. Consult with the local safety codes and standards for additional requirements in your local area.

NOTE: Rear clearance can only be reduced to 300 mm for ventilation when the UPS cabinet is used in push-to-wall installations, typically together with the classic battery cabinet.

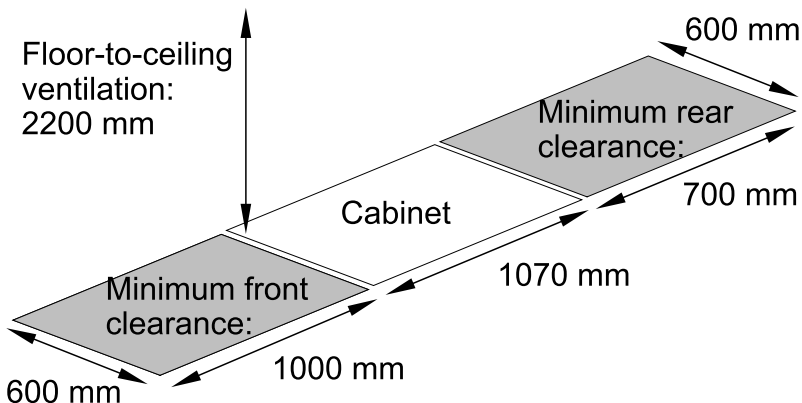

Unpack the Cabinets

NOTE: The shipping materials are recyclable. Save them for later use, or dispose of them appropriately.

1. Cut the plastic wrap along the edges.
2. Remove the plastic wrap and the cardboard covers. Remove the ramps and set aside.

3. Remove the stabilizing brackets from the front, back, and sides of the cabinets.

PDU Cabinet

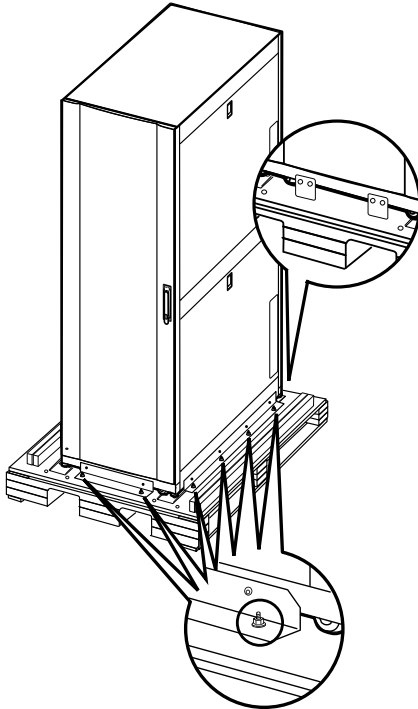

All Other Cabinets

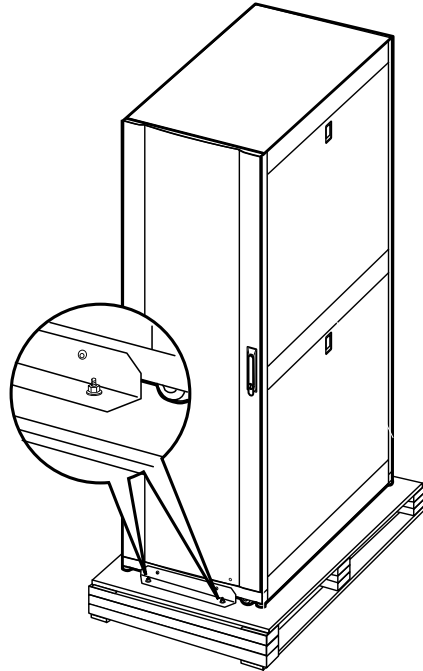

⚠ CAUTION

HAZARD OF INSTABILITY

The product could roll down the ramp too quickly, or the casters could jam into the ramp's guides, causing the product to tip over. To reduce the risk of personal injury, a minimum of two people are required to control the product as it rolls down the ramps. One person should be located in either side of the ramps. In addition, ensure a clear area around the pallet and ramps to have as an escape route in the event the product were to tip over.

Failure to follow these instructions can result in injury or equipment damage.

4. Place the metal taps of the two ramps into the two slots near the edge of the pallet.

PDU Cabinet

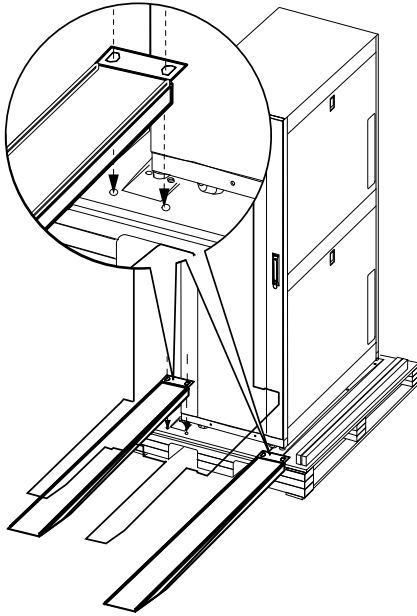

All Other Cabinets

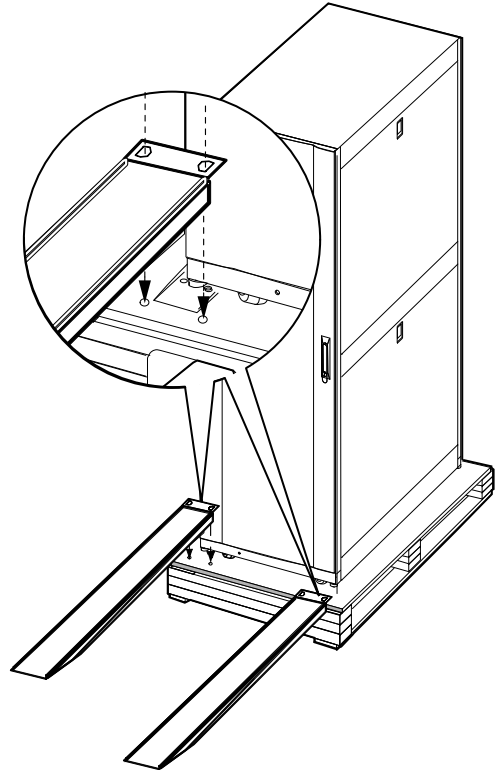

5. Use two people to roll the cabinet off the pallet and guide it down the ramps. Make sure that the metal taps remain in the slots while rolling off the unit.

PDU Cabinet

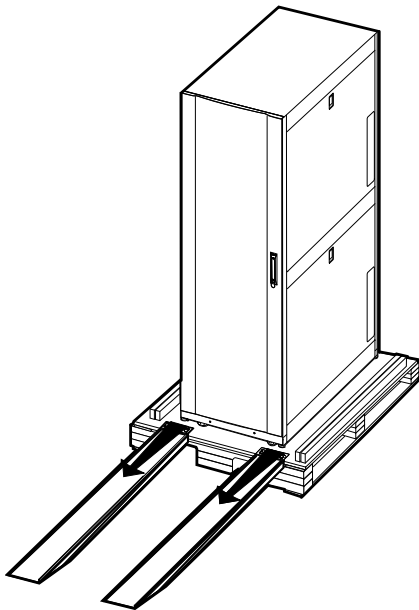

All Other Cabinets

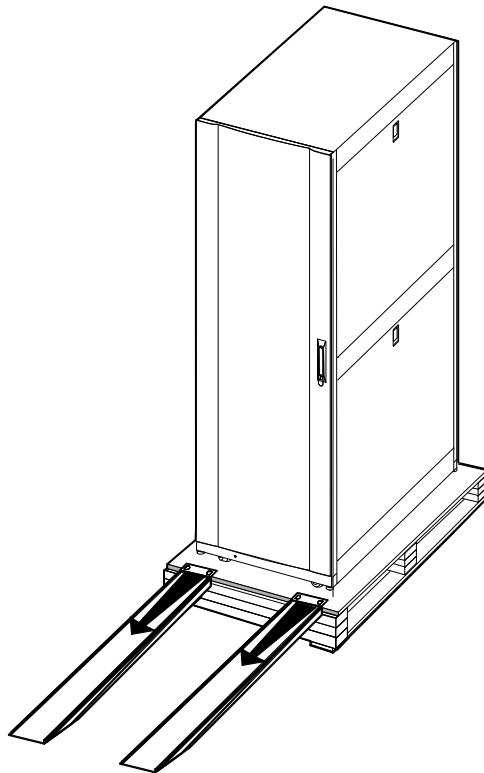

NOTE: After the unit has been removed from the pallet, move it only by rolling it on the casters.

Documentation Storage

48 kW System

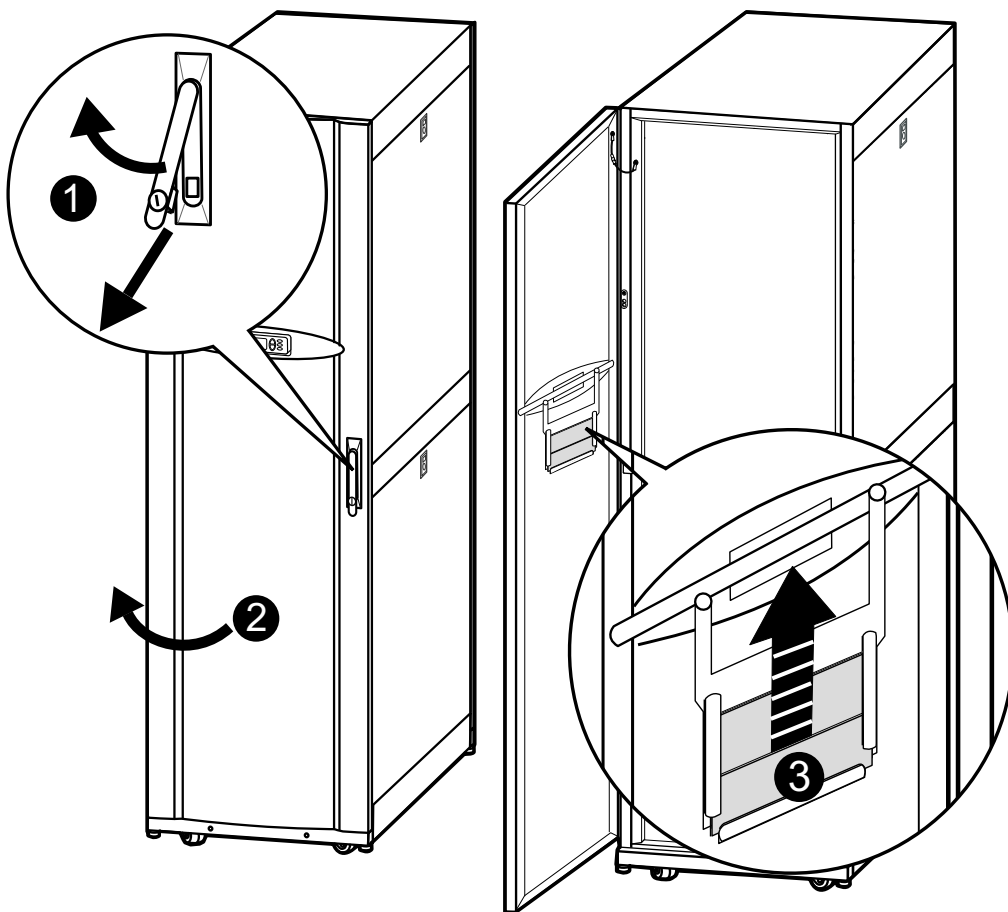

96, 100, and 160 kW Systems

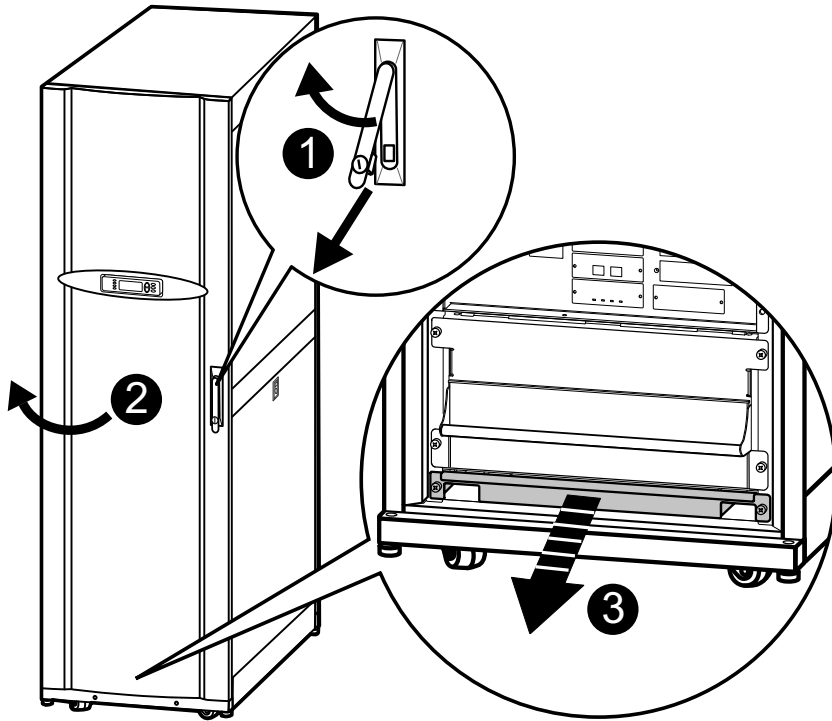

Schneider Electric
35 rue Joseph Monier
92500 Rueil Malmaison
France

+ 33 (0) 1 41 29 70 00

www.schneider-electric.com

As standards, specifications, and design change from time to time, please ask for confirmation of the information given in this publication.

© 2015 – 2023 Schneider Electric. All rights reserved.

990-3013G-001